



(12) UK Patent (19) GB (11) 2 229 865 (13) B

(54) Title of Invention

Electrical propulsion unit for spacecraft

(51) INT CL⁵; F03H 5/00

(21) Application No
8825470.1

(22) Date of filing
01.11.1988

(43) Application published
03.10.1990

(45) Patent published
05.05.1993

(72) Inventor(s)
Roger John Shawyer

(73) Proprietor(s)
**Roger John Shawyer
31 The Drive
Southbourne
Emsworth
Hants
PO10 8JP
United Kingdom**

(74) Agent and/or
Address for Service
**Roger John Shawyer
31 The Drive
Southbourne
Emsworth
Hants
PO10 8JP
United Kingdom**

(52) Domestic classification
(Edition L)
**H1W WX
U1S S1842**

(56) Documents cited
GB1521327 A

(58) Field of search

As for published application
2229865 A viz:
UK CL(Edition K) H1W WX,
H1X X5X
INT CL⁵ F03H, H01P
Online databases: WPI,
INSPEC
updated as appropriate

2229865

1/1

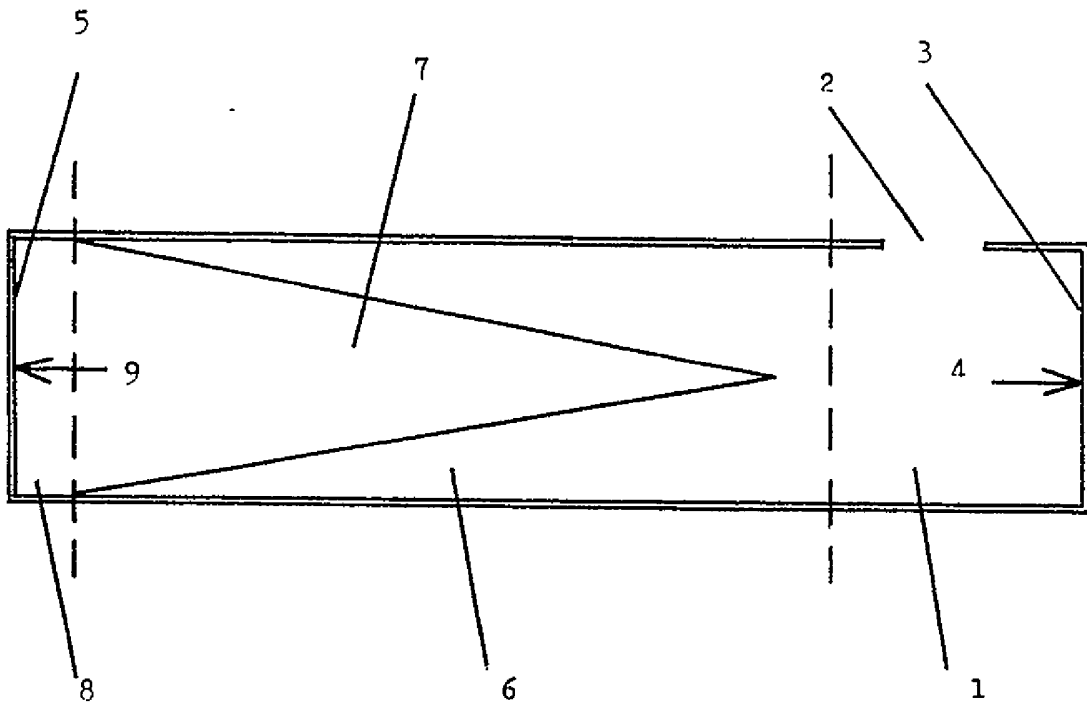

Figure 1

2229865

- 1 -

ELECTRICAL PROPULSION UNIT FOR SPACECRAFT

This invention relates to an electrical propulsion unit for use on spacecraft.

Electrical propulsion is used for maintaining or changing the orbits of spacecraft by applying low levels of thrust over long periods of time.

According to the present invention there is provided a unit which will generate thrust when supplied with electrical energy at the appropriate frequency. The electrical energy will cause electromagnetic waves to be propagated in the unit which comprises a resonant waveguide assembly. The assembly includes both an air or vacuum filled end section and an end section containing a dielectric resonator or ferrite material. The force resulting from reflections of the guided electromagnetic waves in the end section containing a dielectric resonator or ferrite material will be greater than the force resulting from reflections in the air or vacuum filled end section. The difference between these forces will give rise to a resultant thrust on the unit.

A specific embodiment of the invention will now be described by way of example with reference to the accompanying drawing, Figure 1, which shows a schematic diagram of the propulsion unit.

Electrical energy of appropriate frequency is coupled into an air or vacuum filled end section of waveguide 1 by means of a slot or probe 2 depending on the required interface with the energy source. This energy propagates along the waveguide as an electromagnetic wave and is reflected at one end of the air or vacuum filled section by an end wall 3. Reflection of the electromagnetic wave causes a force to be produced on the end wall 3 in the direction of the arrow 4. The electromagnetic wave also propagates towards the other end wall 5 via a transition section 6, containing a shaped element 7 made of an electrical material.

This electrical material will have a relative permeability higher than unity or a relative permittivity higher than unity or both relative permeability and relative permittivity higher than unity. The electrical material will also exhibit low electrical losses. Such an electrical material may be selected from dielectric resonator materials or from ferrite materials.

After propagating along the transition section, the electromagnetic wave enters an end section 8, filled with the electrical material and terminated with an end wall 5. The transition section will be of sufficient length and will contain a suitably shaped element, to enable propagation of the electromagnetic wave to be transferred from the end section 1 to the end section 8, or from the end section 8 to the end section 1, without causing significant reflections of the electromagnetic wave.

The electromagnetic wave is reflected at the end wall 5 and produces a force on the end wall 5 in the direction of the arrow 9. This force is greater than the force at the end wall 3 by a factor dependent on the relative permeability and relative permittivity of the electrical material. The difference

in the forces exerted on the two end walls 3 and 5 will give rise to a resultant force on the propulsion unit in the direction of the arrow 9.

The overall length of the three sections of waveguide 1, 6 and 8 will be a multiple of half the effective wavelength of the applied electrical energy, to enable a resonant state to be established. The total resultant force due to the multiple reflections will be increased by a factor dependent on the electrical losses occurring in the waveguide assembly .

The thrust generated by the unit, due to the total resultant forces, produced as described, can be transmitted to a spacecraft by mechanically fixing the unit together with its source of electrical energy, to the spacecraft structure.

CLAIMS

1 An electrical propulsion unit which will generate thrust when supplied with electrical energy at the appropriate frequency, causing electromagnetic waves to be propagated in the unit which comprises a resonant waveguide assembly and including both an air or vacuum filled end section and an end section containing a dielectric resonator or ferrite material, such that the force resulting from reflections of the guided electromagnetic waves in the end section containing the dielectric resonator or ferrite material will be greater than the force resulting from reflections in the air or vacuum filled end section, the difference between these forces giving rise to a resultant thrust on the unit.

2 An electrical propulsion unit as claimed in Claim 1, with a means of coupling electrical energy of the appropriate frequency into the waveguide assembly such as a slot in the waveguide wall, or a probe inserted into the waveguide.

3 An electrical propulsion unit as claimed in Claim 1 or Claim 2 which includes a transition section of sufficient length and containing a shaped element to enable transfer of the electromagnetic wave between end sections without causing significant reflections of the electromagnetic wave.

4 An electrical propulsion unit as claimed in any preceding claim which includes an end section and a transition section containing a dielectric resonator or ferrite material whose relative permeability or relative permittivity or both have values greater than unity, and whose electrical losses are low at the frequency of the applied electrical energy.

5 An electrical propulsion unit as claimed in any preceding claim whose overall electrical length within the waveguide assembly is a multiple of half the effective wavelength of the applied electrical energy, resulting in a waveguide assembly which is resonant at the frequency of the applied electrical energy.

6 An electrical propulsion unit substantially as described herein with reference to the accompanying drawing Figure 1.
